

N 96 SERIES VACUUM PUMPS AND COMPRESSORS



N 96 KNDC-B-M



N 96 KNE-W



N 96 STDC-B-M

ADVANTAGES

- Copes well with vapor and condensation
- The pump can start against the entire pressure and vacuum range without discharging
- Brushless DC motor for custom-fit rotational speed control
- Extended temperature range for ambient temperatures up to 50 °C and media temperatures up to 70 °C
- High level of gas tightness: 6×10^{-3} mbar x l/s according to type examination
- AC version with multi-voltage power supply input for world-wide use

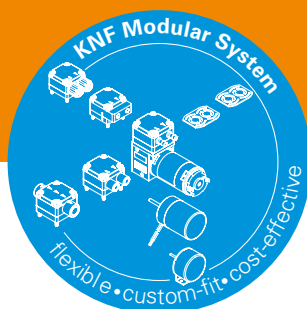

Please visit our website
www.knf.com
to get more information

POSSIBLE AREAS OF USE

- Stationary emission measurement technology
- Mobile/portable gas measurement technology
- Instrumental analysis
- Medical technology – especially diagnostics
- Fuel cells

PERFORMANCE DATA

Series model	N 96						
Material design	KTDC-B-M	KNDC-B-M	KTE-W	KNE-W	ATDC-B-M	STDC-B-M	
Pump head	PPS					Aluminium	Stainless steel
Diaphragm	PTFE-coated	EPDM	PTFE-coated	EPDM	PTFE-coated		
Valves	FKM					FFKM	
Flow rate at atm. pressure (l/min)	7.0 ± 10 %	8.5 ± 10 %	7.0 ± 10 %	8.5 ± 10 %	7.0 ± 10 %		
Ultimate vacuum (mbar abs.)	< 130	< 100	< 130	< 100	< 130		
Max. operating pressure (bar rel./psig)	2.5/36.3						
Permissible ambient temperature (°C)	+5 ... +50 (> 2 bar rel.: +5 ... +40) 0 if frost-free (non-condensing)						
Permissible media temperature (°C)	0 ... +70	0 ... +50	0 ... +70	0 ... +50	0 ... +70		
Weight (kg/lbs)	0.6/1.3		0.7/1.5		0.65/1.4	0.9/2.0	

ELECTRICAL DATA

Voltage (V)	24		100–240		24	
Motor	Brushless DC motor, PWM-signal: 55...0 %	Brushless DC motor, PWM-signal: 30...0 %	Brushless DC motor with AC power supply		Brushless DC motor, PWM-signal: 55...0 %	
Frequency (Hz)	-		50/60		-	
Protection class motor	IP 20					
Power P ₁ (W)	19	23	21	25	19	
I _N (A)	0.9	1.05	0.23 (230 V) / 0.39 (100 V)	0.24 (230 V) / 0.46 (100 V)	0.9	

N 96 KTDC-B-M

PERFORMANCE DATA

Series model	Flow rate at atm. pressure (l/min) ¹⁾	Max. operating pressure (bar rel./psig)	Ultimate vacuum (mbar abs.)
N 96 KTDC-B-M	7.0 ± 10 %	2.5/36.3	< 130

¹⁾ Flow rate determined at 20 °C, 1013 mbar abs. (Pressure 0 to 1013 mbar abs. in accordance with ISO 21360-1/2)

N 96 KTDC-B-M

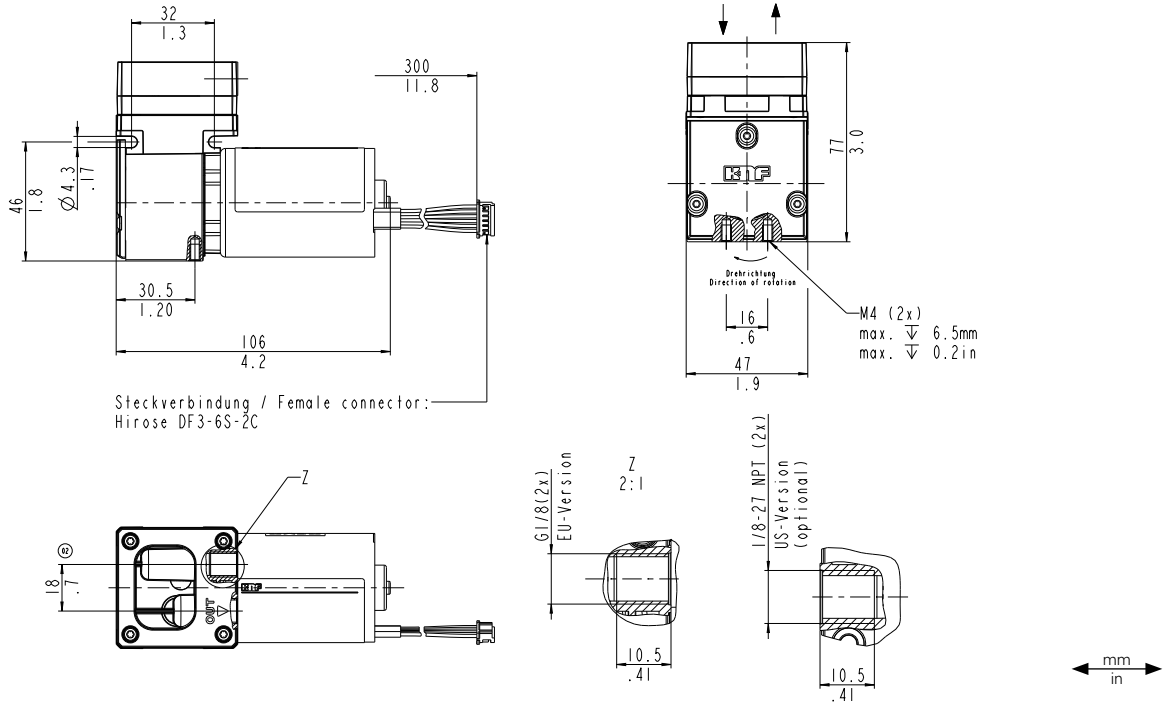

N 96 KTDC-B-M

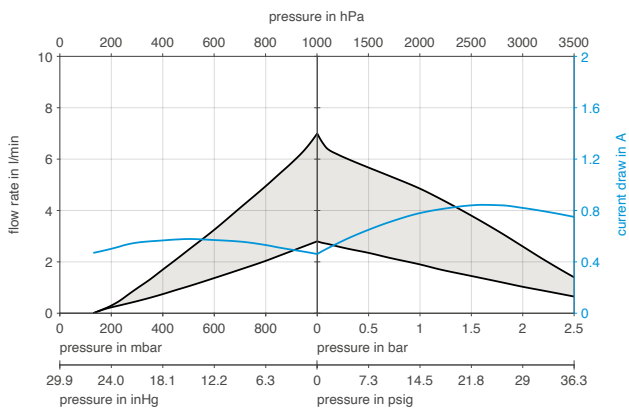

N 96 KTDC-B-M | PUMP UP TIME FOR 5 LITER VESSEL

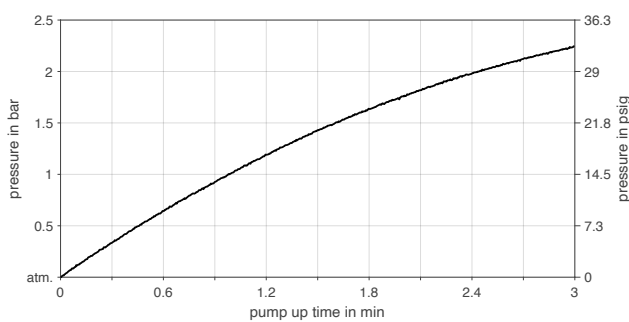

N 96 KTDC-B-M | PUMP DOWN TIME FOR 5 LITER VESSEL

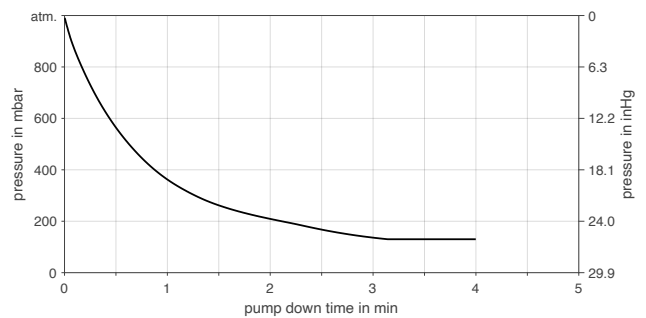

N 96 KNDC-B-M

PERFORMANCE DATA

Series model	Flow rate at atm. pressure (l/min) ¹⁾	Max. operating pressure (bar rel./psig)	Ultimate vacuum (mbar abs.)
N 96 KNDC-B-M	8.5 ± 10 %	2.5/36.3	< 100

¹⁾ Flow rate determined at 20 °C, 1013 mbar abs. (Pressure 0 to 1013 mbar abs. in accordance with ISO 21360-1/2)

N 96 KNDC-B-M

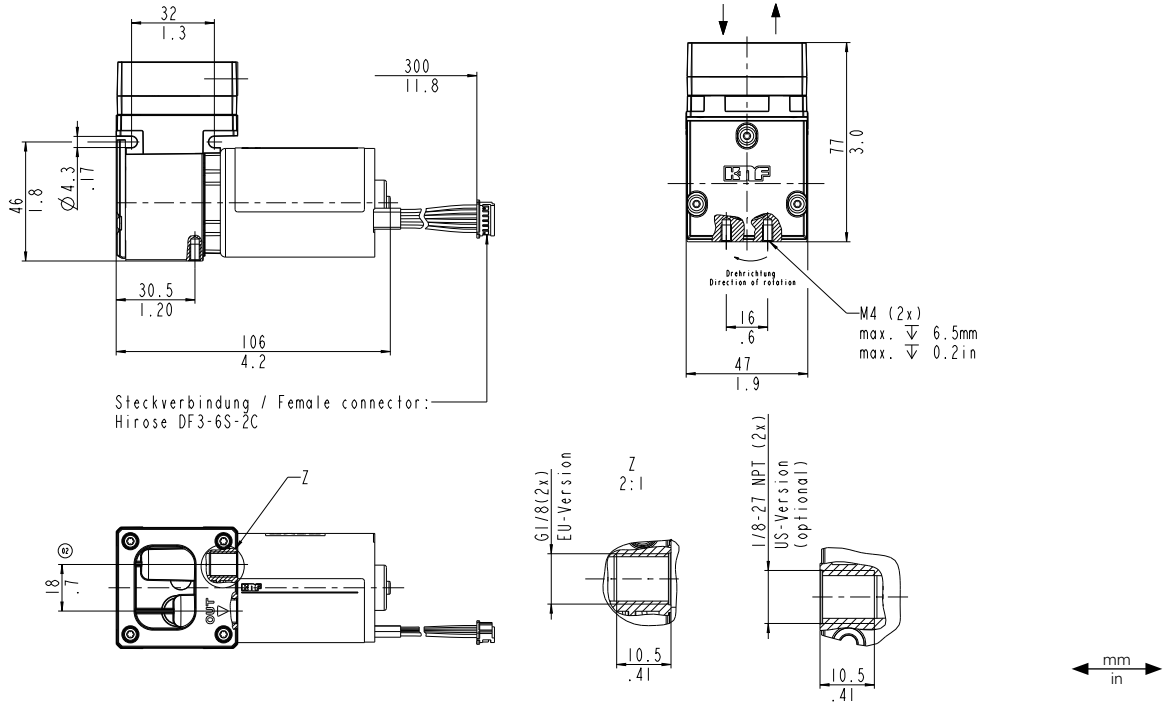

N 96 KNDC-B-M

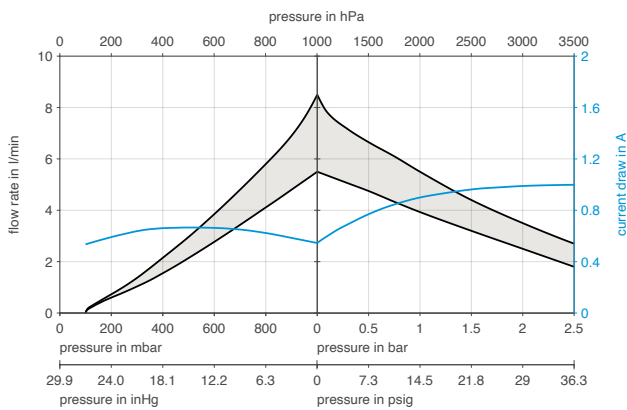

N 96 KNDC-B-M | PUMP UP TIME FOR 5 LITER VESSEL

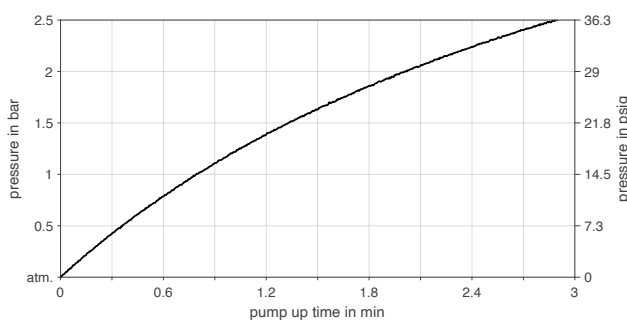

N 96 KNDC-B-M | PUMP DOWN TIME FOR 5 LITER VESSEL

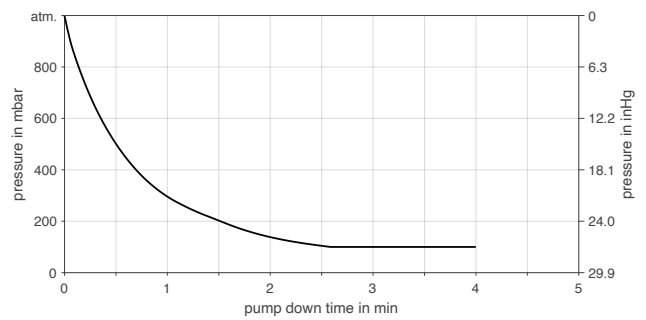

N 96 KTE-W

PERFORMANCE DATA

Series model	Flow rate at atm. pressure (l/min) ¹⁾	Max. operating pressure (bar rel./psig)	Ultimate vacuum (mbar abs.)
N 96 KTE-W	7.0 ± 10 %	2.5/36.3	< 130

¹⁾ Flow rate determined at 20 °C, 1013 mbar abs. (Pressure 0 to 1013 mbar abs. in accordance with ISO 21360-1/2)

N 96 KTE-W

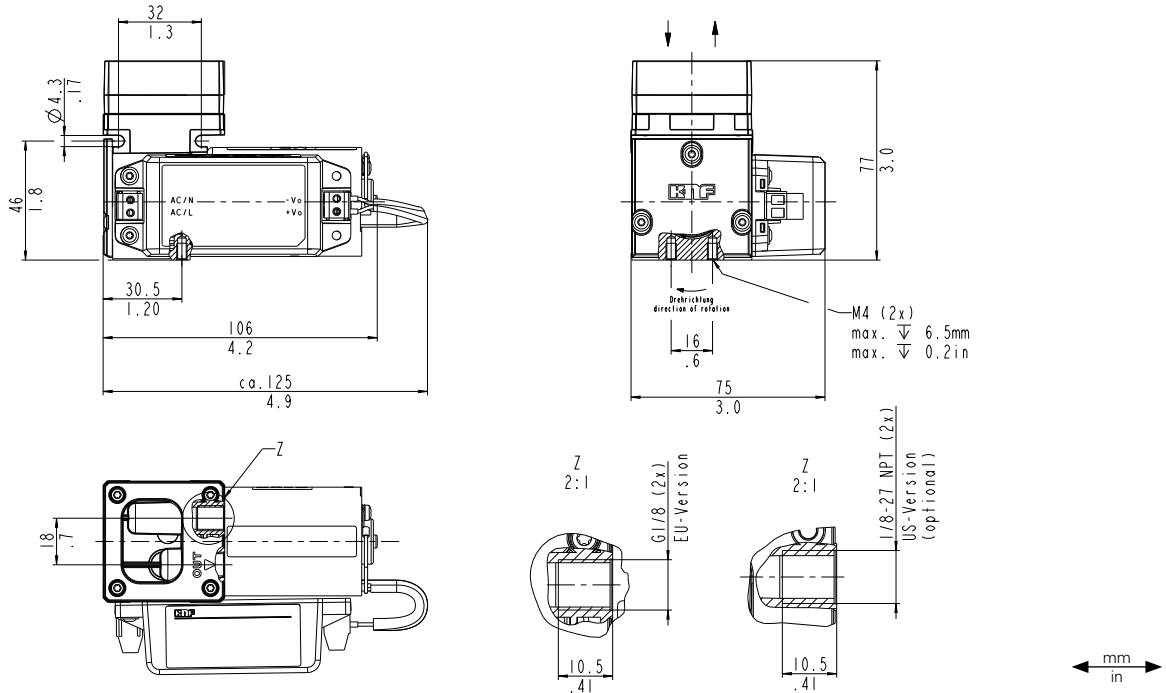

N 96 KTE-W

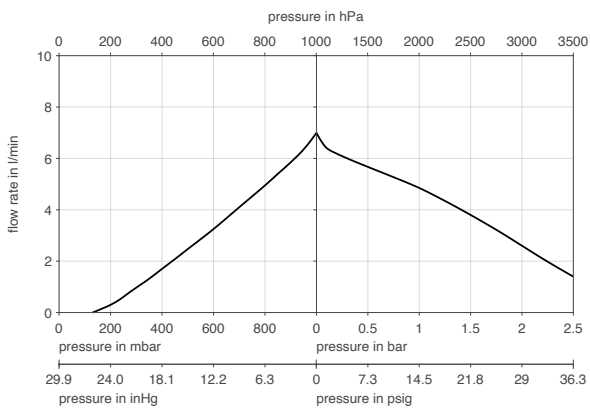

N 96 KTE-W | PUMP UP TIME FOR 5 LITER VESSEL

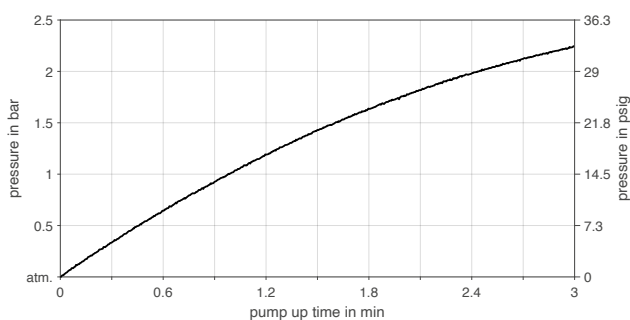

N 96 KTE-W | PUMP DOWN TIME FOR 5 LITER VESSEL

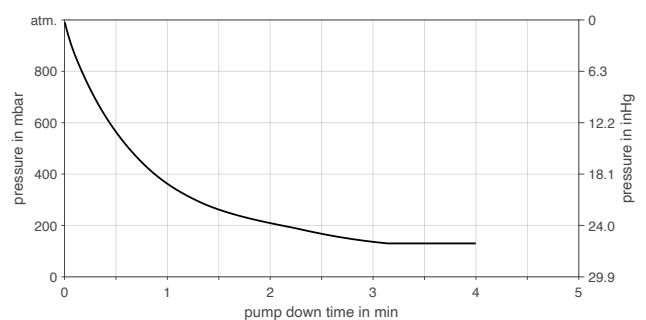

N 96 KNE-W

PERFORMANCE DATA

Series model	Flow rate at atm. pressure (l/min) ¹⁾	Max. operating pressure (bar rel./psig)	Ultimate vacuum (mbar abs.)
N 96 KNE-W	8.5 ± 10 %	2.5/36.3	< 100

¹⁾ Flow rate determined at 20 °C, 1013 mbar abs. (Pressure 0 to 1013 mbar abs. in accordance with ISO 21360-1/2)

N 96 KNE-W

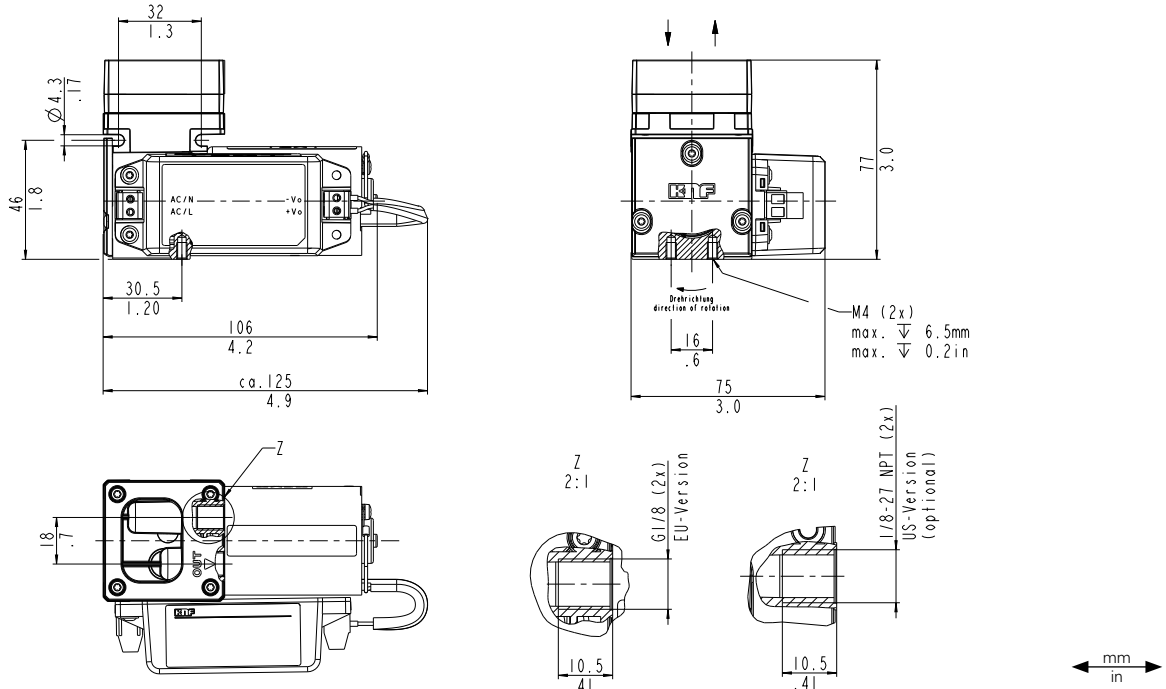

N 96 KNE-W

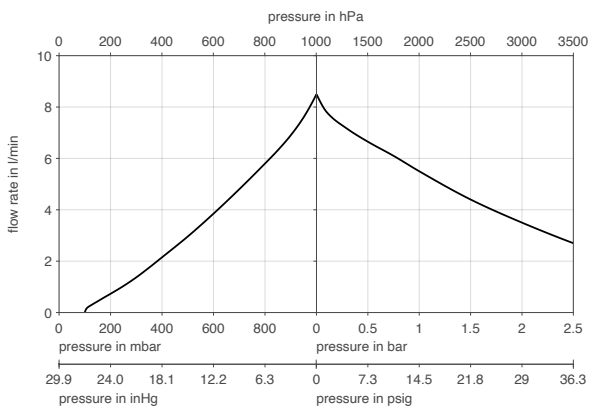

N 96 KNE-W | PUMP UP TIME FOR 5 LITER VESSEL

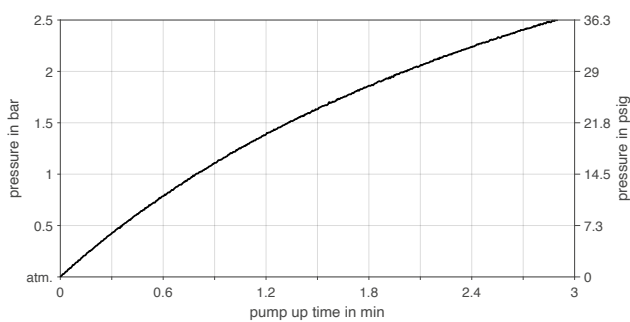

N 96 KNE-W | PUMP DOWN TIME FOR 5 LITER VESSEL

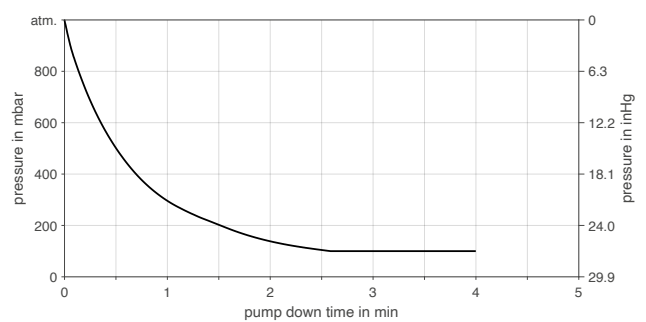

N 96 ATDC-B-M

PERFORMANCE DATA

Series model	Flow rate at atm. pressure (l/min) ¹⁾	Max. operating pressure (bar rel./psig)	Ultimate vacuum (mbar abs.)
N 96 ATDC-B-M	7.0 ± 10 %	2.5/36.3	< 130

¹⁾ Flow rate determined at 20 °C, 1013 mbar abs. (Pressure 0 to 1013 mbar abs. in accordance with ISO 21360-1/2)

N 96 ATDC-B-M

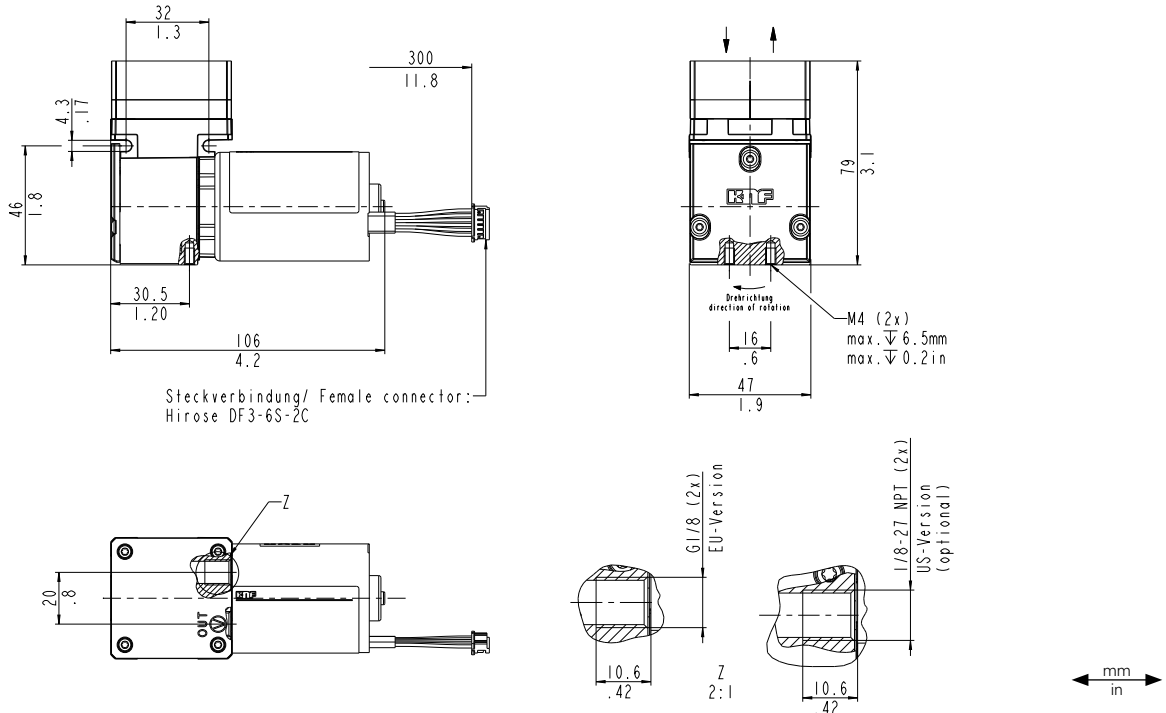

N 96 ATDC-B-M

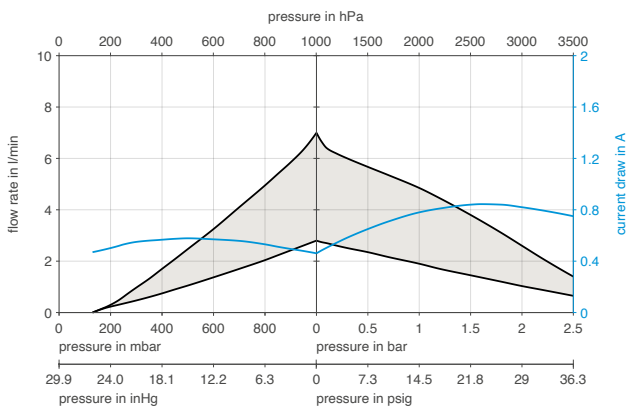

N 96 ATDC-B-M | PUMP UP TIME FOR 5 LITER VESSEL

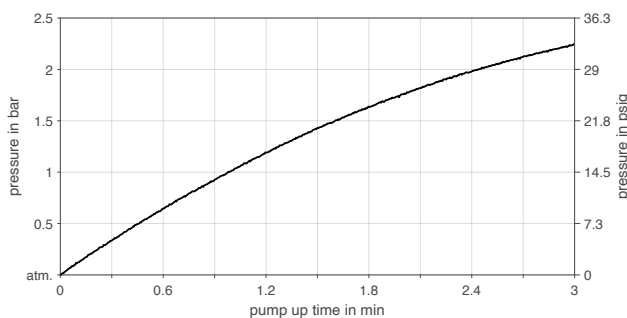

N 96 ATDC-B-M | PUMP DOWN TIME FOR 5 LITER VESSEL

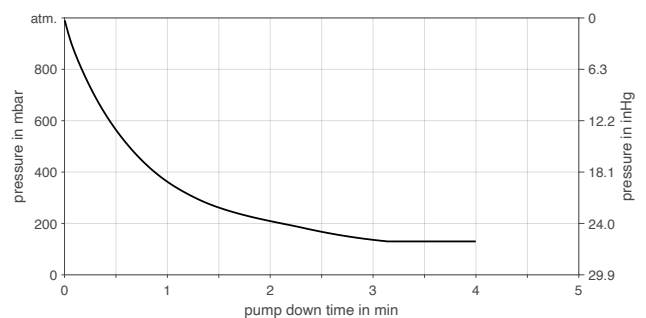

N 96 STDC-B-M

PERFORMANCE DATA

Series model	Flow rate at atm. pressure (l/min) ¹⁾	Max. operating pressure (bar rel./psig)	Ultimate vacuum (mbar abs.)
N 96 STDC-B-M	7.0 ± 10 %	2.5/36.3	< 130

¹⁾ Flow rate determined at 20 °C, 1013 mbar abs. (Pressure 0 to 1013 mbar abs. in accordance with ISO 21360-1/2)

N 96 STDC-B-M

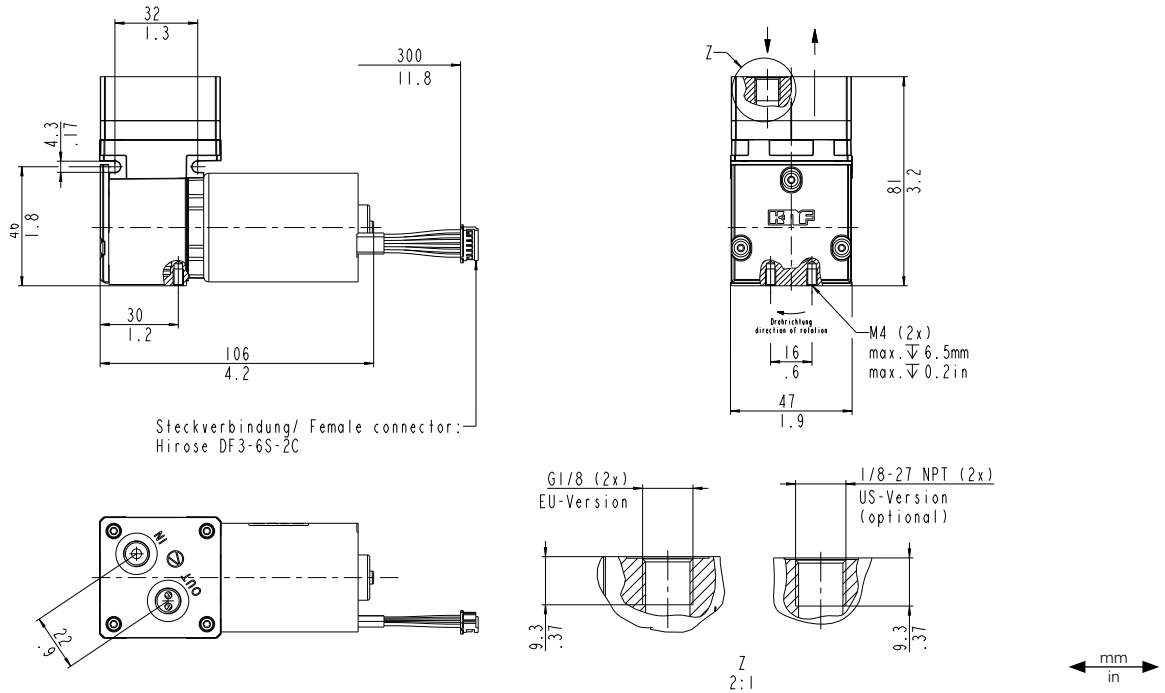

N 96 STDC-B-M

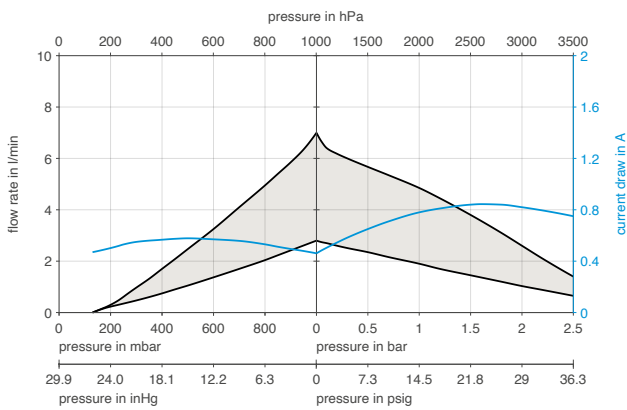

N 96 STDC-B-M | PUMP UP TIME FOR 5 LITER VESSEL

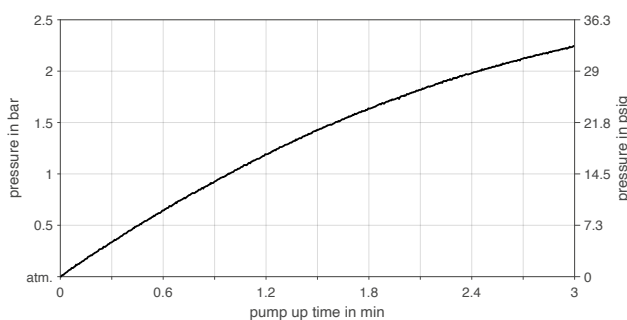

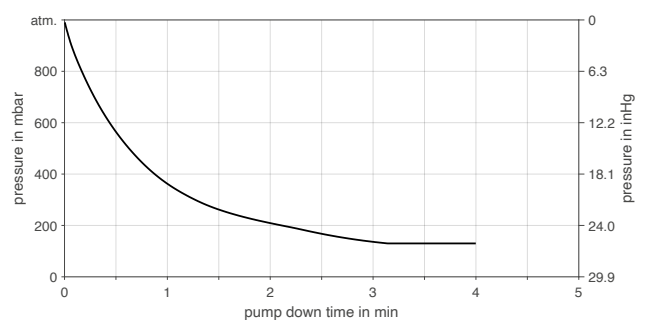

N 96 STDC-B-M | PUMP DOWN TIME FOR 5 LITER VESSEL



ACCESSORIES

Description	Illustration	Part No.	Details
Silencer		000345	G 1/8
Inlet filter		000346	G 1/8
Hose connector ID 4		001936	PA, R 1/8
Hose connector ID 4		025671	PVDF, G 1/8
Hose connector ID 6		020185	PA, G 1/8
Hose connector ID 6		123363	PVDF, G 1/8
Rubber bonded metal		320986	
Mounting kit- base plate + rubber-bonded metals		327888	
Compression fitting OD 6		014049	PVDF, G 1/8
Compression fitting OD 6		311072	Stainless steel, G 1/8

SPARE PARTS

Description	Illustration	Part No.	Details
Spare parts kit N 96 KT and AT version		322636	Spare parts kit consists of: 1 x zone diaphragm, 2 x valve plate. This set is required to maintain the pump.
Spare parts kit N 96 KN version		322637	Spare parts kit consists of: 1 x zone diaphragm, 2 x valve plate. This set is required to maintain the pump.
Spare parts kit N 96 ST version		326868	Spare parts kit consists of: 1 x zone diaphragm, 2 x valve plate. This set is required to maintain the pump.

The performance values for the series models shown on this data sheet were determined under test conditions. The actual performance values may differ and depend in particular on the usage conditions and therefore on the specific application, on the parameters of the components involved in the user's system and on any technical modifications carried out which deviate from the standard configuration or the as delivered condition.

If individual designs have been created for specific customers on the basis of series models, other technical performance data may apply. Before operation begins, the relevant operating instructions and/or assembly or installation instructions should be read and the safety information contained in these instructions should be noted. KNF reserves the right to make changes to the product and the associated documentation without prior notice to the customer.



www.knf.com